

# MECHON



**DEPARTMENT OF MECHANICAL  
ENGINEERING**



# Message from Dean

I am proud to announce the release of 'MECHON' magazine's second issue. The magazine signifies the writer's penmanship and also allows them to share their ideas. I acknowledge the efforts of students and staff of Mechanical department who have taken the initiative to promote the writing and publishing skills of the students. This helps the students to share and express their ideas in an articulate manner.

Students and staff achievements have also been presented which will be a motivational factor for the other students to achieve the standard of excellence. Glad to say that we have achieved our aim of turning this into reality. I would like to congratulate all the students, teachers, alumni and everyone involved in bringing out its 2nd edition.

Wishing everyone loads of success and bright future.

Dr. R. R. Sedamkar



## Message by Mentor Dean

It is a great pleasure and I feel honored to be a part of the second edition of the e-magazine. Only two batches have passed out but students and faculties are showing tremendous potential of growth.

Apart from academic excellence, students have performed at national/international competitive examinations such as GATE, MBA, GRE etc.

This year, SAE(Society of Automotive Engineers) professional chapter is opened. Under that banner, team qualified in BAHA and two more events at national level. All these are possible only because of proper guidance of faculties and support of top management. Department has also encouraged outside project. It has made collaboration with Perpetual Gravity Pvt Ltd for R & D activities.

For overall personality development apart from academic, co-curricular and extra curricular is the need of hour. E-magazine provides the overview of department and growth in all the areas.

At last, I congratulate all faculties, staff and students for presenting and publishing the e-magazine.

Dr. Sanjay Sir



## Message by Head of Department

I am pleased to know that our students are successful in bringing their second issue of magazine MECHON for this academic year 2017-18. MECHON, the departmental magazine has the prime objective of providing aspiring engineers a wide platform to showcase their technical knowledge and to pen down innovative ideas.

This magazine is intended to bring out the hidden literary talents in the students and teachers to inculcate strong technical skills among them. I congratulate and thank all the students and faculty coordinator who have made untiring efforts to bring out this magazine. I wish them all the very best for releasing more such magazines in future.

Dr. Siddesh Siddapa



# Message from Faculty In-charge

It gives me immense pleasure to present the very first issue of “MECHON” magazine of the Department of Mechanical Engineering. It is the talent and outcome of our students which is reflected through this. This is one of the best platforms for our students to present multifaceted personalities and innovative ideas.

I take this opportunity to thank our respected Principal Dr. B. K. Mishra, Dean Academics Dr. R. R. Sedamkar, Dean Mentor Dr. Sanjay Kumar, HOD Dr. Siddesh Siddappa and all the faculty members for their incessant inspiration and kind support.

I believe that this edition, will prove to be a success. I express my heartfelt gratitude to the editorial committee for their relentless efforts, the young writers for their valuable articles and all those who have been a part of “MECHON”.

Mr. Pawan Tiwari



**Department of Mechanical Engineering**

**F A C U L T Y**



# TEAM

Department of Mechanical Engineering

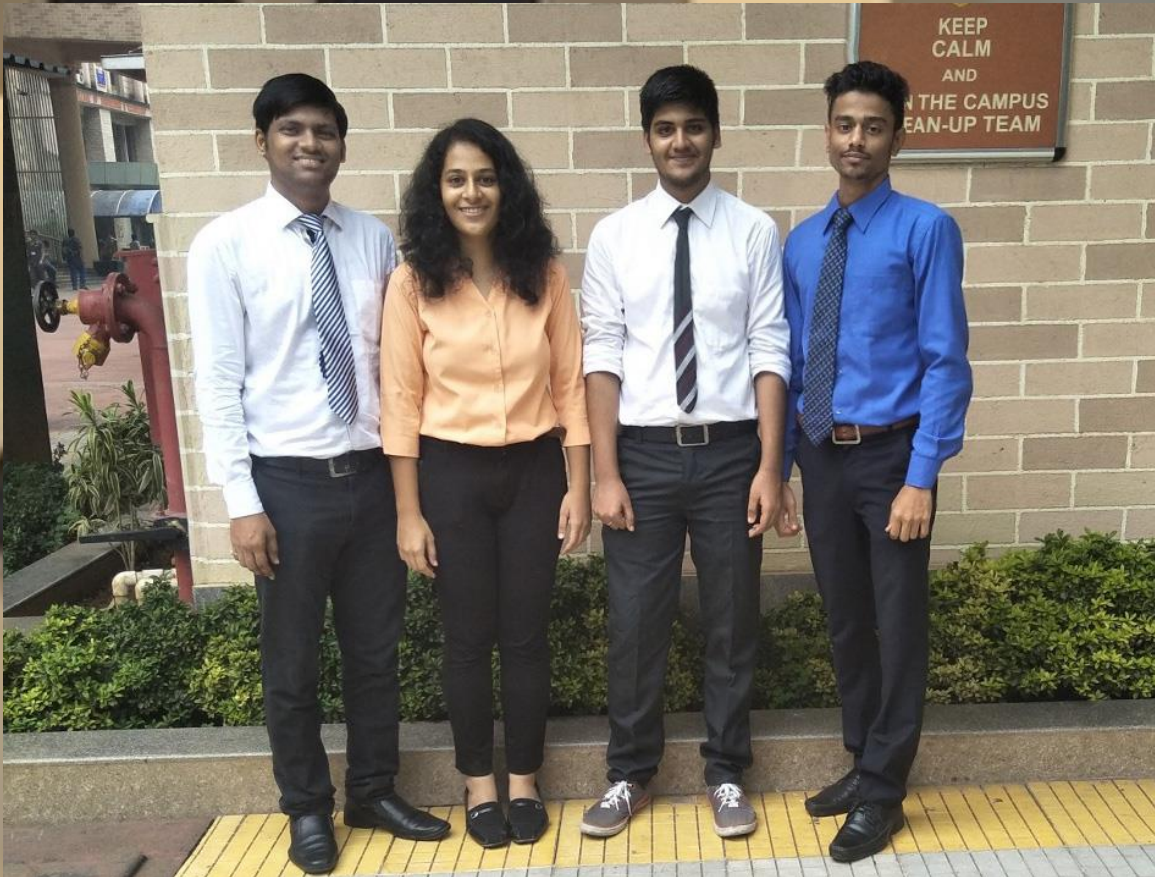

(CHANDRESH - SHIVANI - VISHAL – ABHISHEK )

SHIVANI VELAPURE

CHANDRESH KANSAGRA

ABHISHEK UPADHYAY

VISHAL TIWARI

---



# FACULTY ARTICLES



# Waste Heat Recovery from Domestic Refrigerator

by Mr. Iqbal Mujawar

## I. INTRODUCTION:

Waste heat is heat, which is generated in a process by way of fuel combustion or chemical reaction, heat removed from thermal system by heat exchanger and then “dumped” into the environment even though it could still be reused for some useful and economic purpose. The essential quality of heat is not the amount but rather its “value”. The strategy of how to recover this heat depends in part on the temperature of the waste heat gases and the economics involved.



Use of waste heat recovery is an important technique of reducing total energy costs in energy system design. Attachments need to be developed to recover waste heat energy from air conditioning or refrigeration systems. If the heat recovery system is designed optimally and implemented in residential and small-scale commercial systems, the cumulative benefits would be significant

Households need both refrigeration and water heating. Refrigeration at temperatures below 4°C is employed for food preservation, while hot water at temperatures around 55°C is used for bathing and showering. But it is common for refrigeration and water heating to be separated and unconnected, each consuming their own purchased energy.

A more efficient use of this electrical energy would be to integrate the refrigeration and hot water systems. This would reduce the electrical power consumed by heating water, by making use of the heat rejected by refrigerators.

A home's single largest electricity expense is water heating, which typically accounts for about 40% of their electricity usage. The total energy consumption by geysers will continue to increase as the population grows. As electricity demand increases, the adverse environmental effects and the economic costs associated with electricity generation will also increase.



The vapour compression refrigeration cycle is a common method for transferring heat from a low temperature to a high temperature.

The figure shows the objectives of refrigerators and heat pumps. The purpose of a refrigerator is the removal of heat, called the cooling load, from a low-temperature medium. The purpose of a heat pump is the transfer of heat to a high-temperature medium, called the heating load. When we are interested in the heat energy removed from a low-temperature space, the device is called a refrigerator. When we are interested in the heat energy supplied to the high-temperature space, the device is called a heat pump.

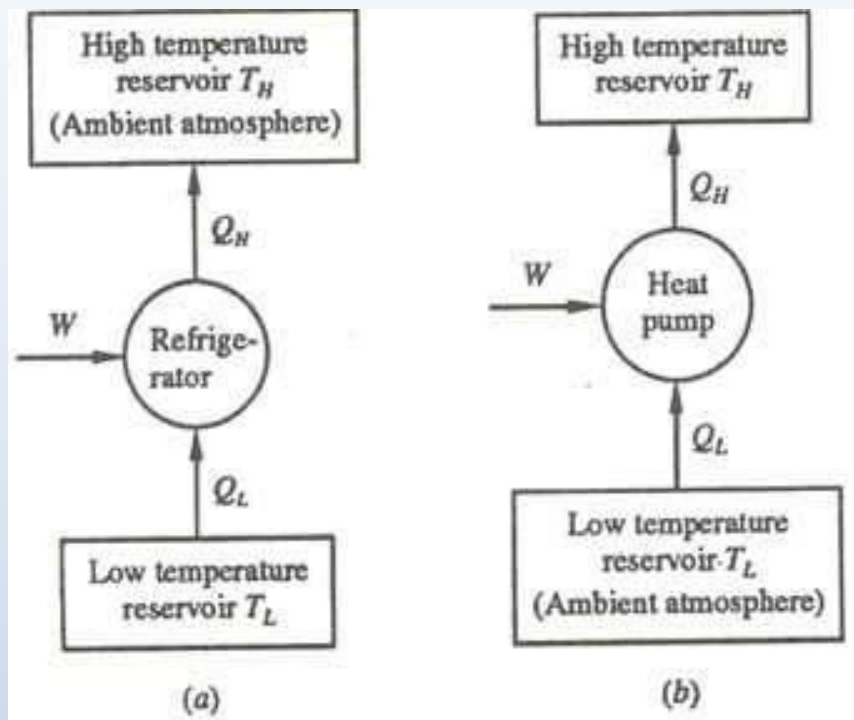

In general, the term heat pump is used to describe the cycle as heat energy is removed from the low-temperature space and rejected to the high-temperature space.

Both refrigerators and heat pumps move heat from a cold thermal reservoir to a warm thermal reservoir. The objective of refrigerators is to remove heat from a cold space whereas the objective of heat pumps is to put heat into a warm space. Both heat pumps and refrigerators use the same thermodynamic cycle and principles.

When a household refrigerator is operating, it rejects heat into the environment at the condenser and in warm climates that heat is usually wasted. In this paper, the feasibility of a new system which used the rejected heat at the condenser of the refrigerator to heat water in the geyser was investigated. Thus, a combined refrigerator/heat exchanger and geyser resulted in a single machine which maintained a certain physical space at cold temperature for storage of food and used the heat rejected by the refrigeration part for water heating.

The figure shows that a vapour compression cycle was used with the evaporator in the refrigerator and condenser in the heat exchanger which was connected to the geyser. Cold and low pressure refrigerant gas entered the compressor where its pressure (and temperature) increased. After the compressor, it then passed through the condenser where it gave up heat at approximately constant pressure to the water in the geyser so that the refrigerant's temperature decreased sufficiently for it to condense into a sub cooled liquid.

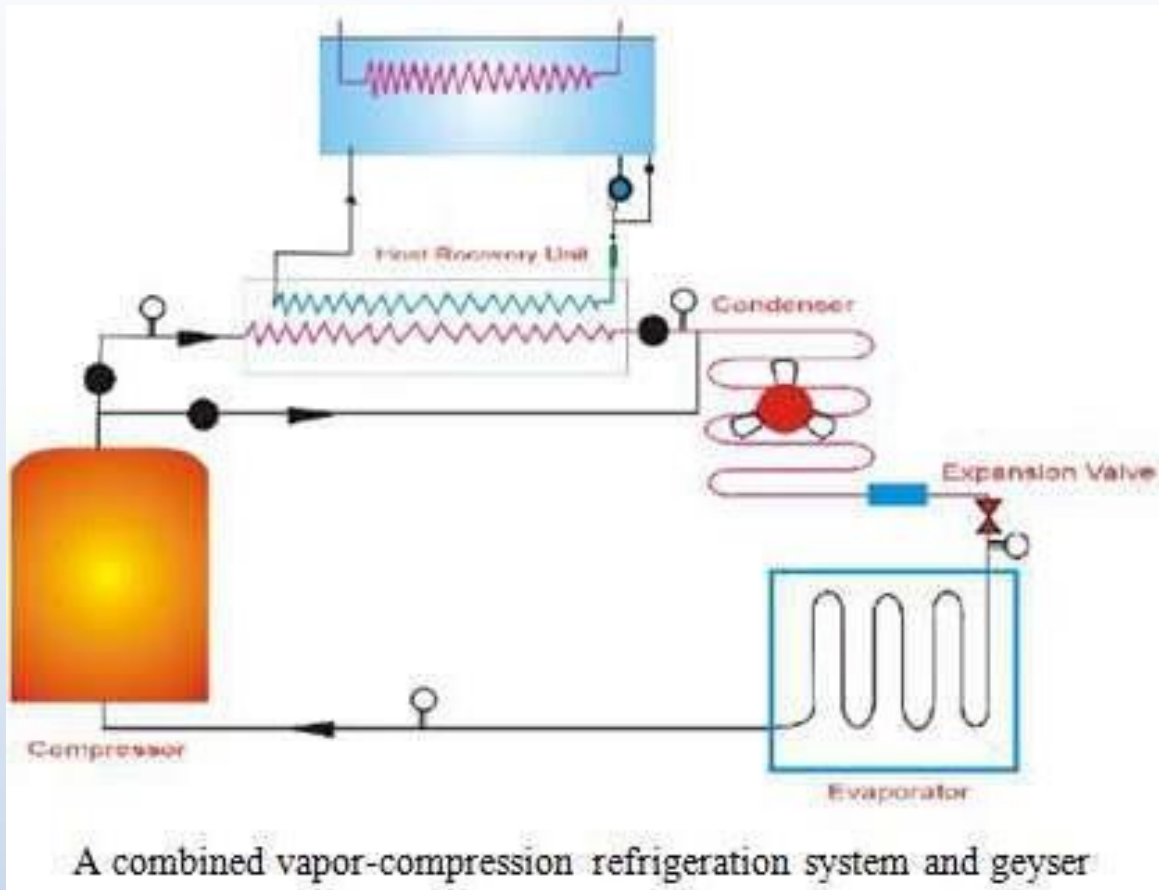

After leaving the condenser it went through an expansion valve (which may be a capillary tube). The decrease in pressure in the expansion process caused the refrigerant to turn back into a mixture of liquid and vapour but at a much lower temperature. Then it went to the evaporator where it absorbed heat at approximately constant pressure from the food in the refrigerator.

## II. LITERATURE REVIEW

Clark et al.1996, describe the design, construction, and testing of an integrated heat recovery system which has been designed both to enhance the performance of a residential refrigerator and simultaneously to provide preheated water for an electric hot water heater. A commercial, indirect-heated hot water tank was retrofitted with suitable tubing to permit it to serve as water cooled condenser for a residential refrigerator. This condenser operates in parallel with the air-cooled condenser tubing of the refrigerator so that either one or the other is active when the refrigerator is running. The refrigerator was housed in a controlled-environment chamber, and it was instrumented so that its performance could be monitored carefully in conjunction with the water pre-heating system.

The system has been tested under a variety of hot water usage protocols, and the resulting data set has provided significant insight into issues associated with commercial implementation of the concept. For the case of no water usage, the system was able to provide a 35 °C temperature rise in the storage tank after about 100 hours of continuous operation, with no detectable deterioration of the refrigerator performance. Preliminary tests with simulations of "high water usage," "low water usage," and "family water usage" indicate a possible 18-20% energy savings for hot water over a long period of operation. Although the economic viability for such a system in a residential environment would appear to be sub-marginal, the potential for such a system associated with commercial-scale refrigeration clearly warrants further study, particularly for climates for which air conditioning heat rejection is highly seasonal

Stinson et al. 1987, conducted research in dairy refrigeration by recovering the heat from condenser. A theoretical energy balance was conducted, from which the potential for recovery of refrigeration condenser heat was estimated to be up to 60% of the water heating energy requirements. Preliminary tests with heat exchangers led to the development and testing of a tube-in-tube, counter flow heat exchanger, with fins on the refrigerant side and cores on the water side to improve the heat transfer characteristics. The exchanger, designed to provide 300 l of water at 60°C from a 2.25 kW refrigeration system which cooled 2100 l of milk per day, had a surface area on the refrigerant side of 0.84, and an overall thermal conductance of 750 W m<sup>-2</sup>C<sup>-1</sup>.

It was inserted between the compressor and the condenser of the refrigeration plant and tested with two condensing systems (air and water), together with varying conditions of condenser pressure and milk temperatures at inlet and final cooling. In addition, tests on the receiver pressure and suction superheat were performed to determine their effect on the overall system performance. Increasing the condenser pressure from 6.5 bar to 12 bar increased cooling times. In extreme circumstances the system failed to comply with the New Zealand milk cooling regulations. The average coefficient of performance (C.O.P.) of the refrigerator (with the heat exchanger in the circuit) decreased with increasing pressure, varying from 3.0 to 2.3 over this range of pressures for the water cooled condenser system. Values for the air cooled condenser system were 0.3 to 0.4 lower due to fan power consumption.

Sanmati Mirji 2006, presented a multipurpose warming apparatus utilizing the waste heat of domestic refrigerator. The multipurpose apparatus was constructed as an additional part of the refrigerator. It used the waste heat generated by the refrigerator and has several possible household uses like food warming, domestic fermentation purposes such as curd making, fermentation for Indian food. The maximum temperature of the chamber got as high as 50°C and the average temperature was around 40 °C. The main advantage of the invention was to keep cooked food warm for a sufficiently long duration before consumption as well as warming the food removed from the refrigerator before consumption. It makes use of the waste heat generated by the domestic refrigerator and does not need any additional power supply.

Mills 1986, investigated several methods of heat recovery as applied to a residence. One of the more interesting approaches involved the reclamation of heat from water after it has been utilized. Waste water is collected in a 454 litre holding tank, which also contains the evaporator for a 1.2 kW water-to-water heat pump. When the water temperature in the holding tank rises above a certain point, the heat pump is activated, transferring heat from the holding tank to the condenser which is mounted inside a 272 litre fresh hot water storage tank. An experimental prototype of this system was constructed and tested using a water usage pattern that was derived from an accepted standard hot water delivery schedule. The tests indicated that an energy savings of up to 60% over a typical 272 litre electric hot water heater was possible.



# Simulations

by Mr. Mahendra Shelar

## Automotive

The automotive industry has undergone profound changes in recent years. Cars need to be more fuel-efficient and environmentally friendly. Traditional combustion engines are being replaced by fuel cells, batteries, opposed-piston technologies or electric traction motors. Innovations come at a high cost, while customers always want the latest innovations at the lowest price.

Innovations require lots of testing using expensive prototypes and equipment. This is where mechanical simulation comes into its own by providing efficient ways to simulate any automotive part or system with a lower overall cost and less time.

Simulation provides an efficient platform for both simulation analysts and designers in one interface, improving the communication between the teams and allowing designers to perform simple simulations upward in the automobile design process. Also provides all types of high end analysis (linear, nonlinear and dynamic) in the same work environment, eliminating the tedious task of platform changing for specific analysis (Crash, Impact, Fluid dynamics...)

## Vehicle door stiffness analysis

### Introduction

Door assembly is a very important part in vehicle design because its frequent interaction with outside world. Designers faces so many different problems during the vehicle door design such as weight, cost, excessive reinforcement, water leakage, and etc. FEA analysis can help designers to reduce lead time as well as cost of design and meet various design goals.

This article introduces two common analysis types performed on vehicle doors Simulation software: Door vertical stiffness analysis and door shell stiffness analysis

### Door vertical stiffness analysis

To perform door vertical stiffness analysis, 3 principle issues need to be considered: Firstly, identify deflection between door and vehicle body due to door's weight. Secondly, identify total deformation and permanent deformation due to excessive vertical load applied to the door by careless user.

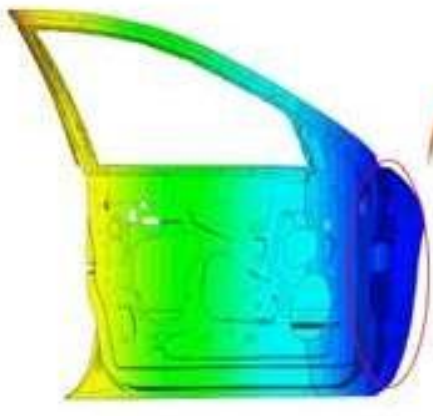

Vertical displacement distribution

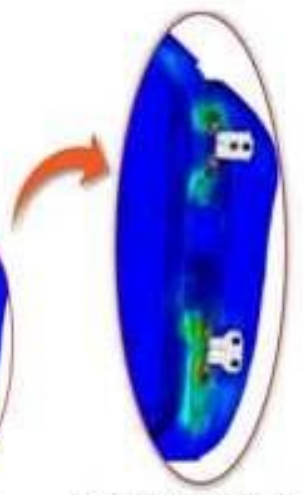

Stress distribution (Hinge)



Thirdly, perform vertical load at door latch when door hinge is restrained. By considering these issues, a finite element model is generated as above picture. Above analysis is performed by Simulation Software linear static analysis. From the result we can see displacement and stress distribution. By observing stress at hinge part we can identify if inner panel is damaged.

### Door shell stiffness analysis

Now we'll discuss door shell stiffness analysis. 2 major issues in door shell stiffness analysis are:

Firstly, stiffness needs to reach a certain level because of the high frequency of contact with the outside of the door shell. Secondly, check the deformed shape and permanent deformations due to user's behavior such as kicking the door.

Vertical Rigidity of Fixture



Look at the graphic above. At first the deflection is quite small due to door's self weight. However this deflection become larger when excessive vertical load is applied. Check the elasticity restoration when load is removed and make sure permanent deformation

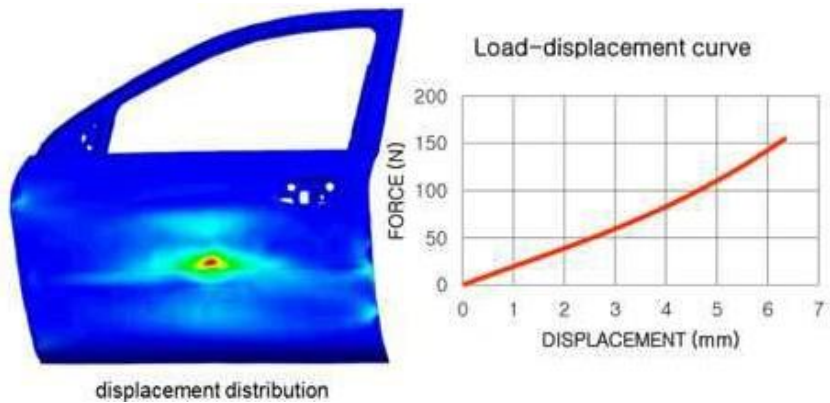

Above analysis is performed by midas NFX linear static analysis. Picture shows door shell's deformation when force is applied to the middle of the car door. And through the load - displacement curve, we can identify the stiffness of the car door shell

# Was it Designed?

by Mr. Jason D'Mello

The boxfish has a sleek design. The contours of his body allow him to swim up to six body lengths per second. The boxfish's surprisingly streamlined form inspired Mercedes-Benz's bionic concept car which is able to perform as high as 70 miles per gallon. Mercedes-Benz decided to model the Bionic after this fish due to the supposed low coefficient of drag of its body shape and the rigidity of its exoskeleton; this influenced the car's unusual looks. Other parts of the design include the fact that the rear wheels are partially fitted with plastic and that it's considered as a lightweight vehicle. Mercedes-Benz reported a drag coefficient of 0.19;<sup>[2]</sup> for comparison, the production vehicle with the lowest ever Cd value was the GM EV1, at 0.195. While the Bionic had a much larger internal volume than the EV1, the Bionic's larger frontal area made the EV1 more aerodynamic overall, as drag is a product of the area and the drag coefficient. What do you think? Did the energy-efficient boxfish come about by chance? Or was it designed?



The thorny devil lizard When threatened, the reptile splays its legs wide, lowers its head menacingly and arches its spike-covered back like a tank ready for war. Oddly, the reptile assumes much the same posture during summer rains. Thorny devil lizard of the arid Australian desert is able to convey water through its body to its mouth. All this creature needs to do is find some moist sand, and the moisture will be wicked up the lizard's leg and will make its way to its mouth. Scientists hope to make a thorny-devil-inspired device that will help people collect lifesaving water in the desert. The reptile draws the water –by capillary action–through hair-thin channels between scales on its body that extend all the way to its mouth. The creature does not have to move, just swallow. Horned lizards use their water-channeling hide to suck moisture right out of the sand and, in defiance of gravity, carry water up to their mouths. What do you think? Did the moisture-extracting skin of the thorny devil come about by evolution? Or was it designed?

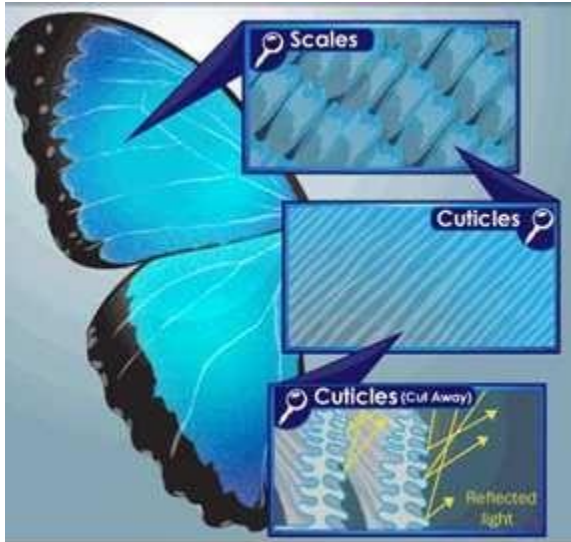

The same principle behind soap bubbles applies to butterfly wings. Their wings, however, amplify the effects of iridescence because they have many more layers for the light to pass through and thus many more opportunities for the light waves to reflect and magnify one another. As small as they are, butterfly wings are covered by thousands of microscopic scales, split into two to three layers

-- thus their Greek order name, Lepidoptera, meaning scaled wings. In turn, each scale has multiple layers separated by air. Rather than having just the constructive interference from the top and bottom layer that you have in a bubble, the many, equally spaced layers of butterfly wings create multiple instances of constructive interference. Iridescence in butterflies and beetles and anti-reflective coatings in moth eyes have resulted in studies that have led to brighter screens for cellular phones and even an anti-counterfeiting technique. What do you think? Did the butterfly's wing come about by evolution? Or was it designed?

Flippers on humpback whales (*Megaptera novaeangliae*) have non-smooth leading edges, yet demonstrate superior fluid dynamics to the characteristically smooth leading edges of our wings, turbines and other kinds of blades.

Whereas sheets of water flowing over smooth flippers break up into myriad turbulent vortices as they cross the flipper, sheets of water passing between a humpback's tubercles maintain even channels of fast-moving water, allowing humpbacks to keep their "grip" on the water at sharper angles and turn tighter corners, even at low speeds. Wind tunnel tests of model humpback flippers with and without leading-edge tubercles have demonstrated the fluid dynamic improvements tubercles make, such as a staggering 32% reduction in drag, 8% improvement in lift, and a 40% increase in angle of attack over smooth flippers before stalling. What do you think? Did the flipper of the humpback whale come about by evolution? Or was it designed?







# STUDENT ARTICLES



# Thermally Stratified Compression Ignition

Ritu Shah (TE MECH B)

## A new advanced low temperature combustion mode with load flexibility

Low temperature combustion is a combustion concept that bears simultaneous reductions in pollutant emissions as well as fuel consumption.. In Homogeneous Charge Compression Ignition a homogeneous blend of fuel and air is compressed until it auto-ignites. This method pairs the high efficiencies of conventional diesel compression ignition combustion with the homogeneous low soot attributes of typical spark ignition combustion. Through higher levels of dilution with air or residuals, engine-out NOx emissions are kept low. Reference to these factors, Homogeneous Charge Compression Ignition has exhibited near zero NOx and soot emissions paired with efficiencies similar to conventional diesel combustion. Unfortunately, this approach is only achievable over a narrow, part-load operating range owing to lack of direct control over the start heat release rate , depend on a direct fuel injection event to initiate a stratification of equivalence ratio and therefore, mixture reactivity. This approach can be effective, but unfortunately, the fuel-air

Mixture in homogeneities pose a risk of higher particulate matter as well as NOx emissions. Instead of trying to use forced fuel-air mixture stratification to control the heat release rates in low temperature combustion, Benjamin Lawler at Stony Brook University in collaboration with Derek Splitter, James Szybist, and Brian Kaul at Oak Ridge National Laboratory proposed a new combustion mode that controls the amount of thermal stratification in low temperature combustion. The method, termed as Thermally Stratified Compression Ignition, , implements direct water injection to control the temperature distribution and mean temperature in the cylinder. Therefore, this approach offers control over the start and rate of heat release in low temperature combustion. Their work is published in *Applied Energy*. “While other researchers are unanimously pursuing approaches that stratify the equivalence ratio in the cylinder using direct fuel injection, we propose an alternative approach that intentionally stratifies the temperature distribution in the cylinder.”

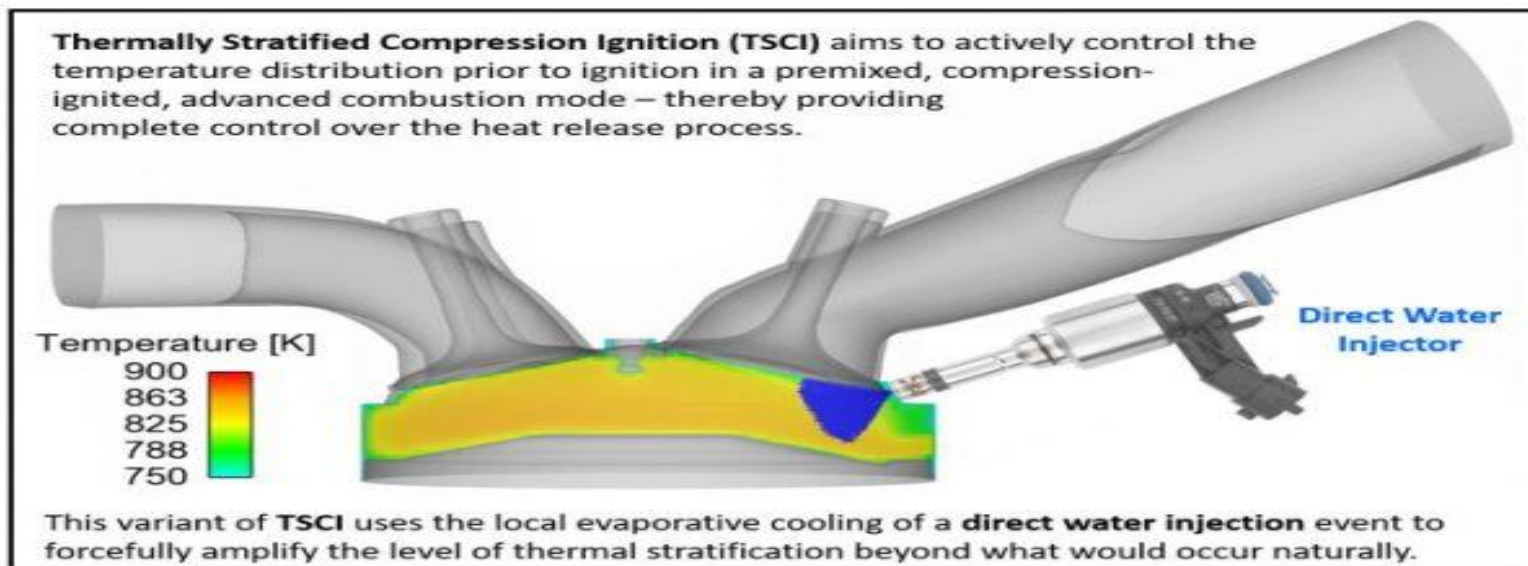

Benjamin Lawler said on Thermally Stratified Compression Ignition.

The authors adopted their proposed advanced combustion mode, Thermally Stratified Compression Ignition. The method used direct injection of water to control the start as well as rate of heat release in low temperature combustion. The main aim of the study was to better understand the impact of water injection on low temperature combustion, with particularity on the comparison between operation with and without water injection. There was also a focus on the effects of water injection amount and timing. At the end, the authors determined the load limits with and without water injections. The research team observed that adding water retards combustion phasing owing to the latent heat of vaporization of water, which subsequently cooled the mixture. The amount of phasing retard was proportional to the amount of water injected. For this reason, water injection could be used for cycle-to-cycle control of the start of heat release in low temperature combustion. Direct water injection in the range of 20-70 degrees before top dead center reduced the rate of heat release by cooling the mixture in the regions targeted by the spray. This forcibly amplified the level of thermal

stratification in the cylinder. Direct water injection could therefore be used for cycle-to-cycle control over the rate of heat release in low temperature combustion. Reference to this, the high load limit was improved from 3.6 bar for Homogeneous Charge Compression Ignition to about 8.4 bar Indicated Mean Effective Pressure in Thermally Stratified Compression Ignition.

“By taking a fundamentally different approach to control over the heat release process in low temperature combustion, Thermally Stratified Compression Ignition is able to significantly expand the operable load range of low temperature combustion and enable a clean, high efficiency, combustion mode over the full operating range. Furthermore, Thermally Stratified Compression Ignition and other low temperature combustion modes are fuel independent, meaning that they can be paired with sustainable biofuels or electrofuels to produce a completely carbon-neutral, efficient, and clean transportation and power generation solution.”, Lawler said.

The outcomes of their study present the potential of water injection to allow for cycle-to-cycle control over the start and rate of heat release in low temperature combustion, therefore, resolving the major limitation of pure Homogeneous Charge Compression Ignition combustion.



# DRIVERLESS CAR

BY Rhishkesh Ludbe (TE Mech A)

## ABSTRACT

There are many paradigm shifts taking place due to information explosion and the concept of autonomous vehicle is one shift. The car, which is embedded, can simulate the human driver completely and direct the vehicle on the road. Autonomous vehicle is the drastic change in technical brilliance and developments in different fields with EMBEDDED SYSTEM as pioneer. Waymo is an autonomous car development company spun out of Google's parent company, Alphabet [Inc.](#), in December 2016. It then took over the self-driving car project which Google had begun in 2009. Alphabet describes Waymo as "a self-driving tech company with a mission to make it safe and easy for people and things to move around". The new company, which will be

headed by long-time automotive executive John Krafcik, is working towards making self-driving cars available to the public soon.

## THE FINE ART OF AUTOMATION

A fully computerized car capable of doing almost everything a car lover would want to. Almost all automobiles will interact with computer on dashboards. From ordering pizza to booking tickets at the nearest theatre, things would be as easy as giving orders to your servant. As a matter of fact, vehicles all over the world are now fitted with intelligent devices that make the vehicles to respond to various factors - be it climate control, sudden accelerations or braking or even self-repair of modules.

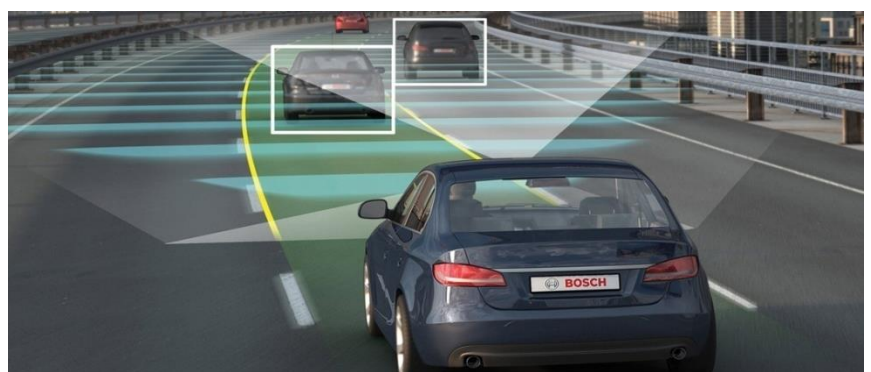

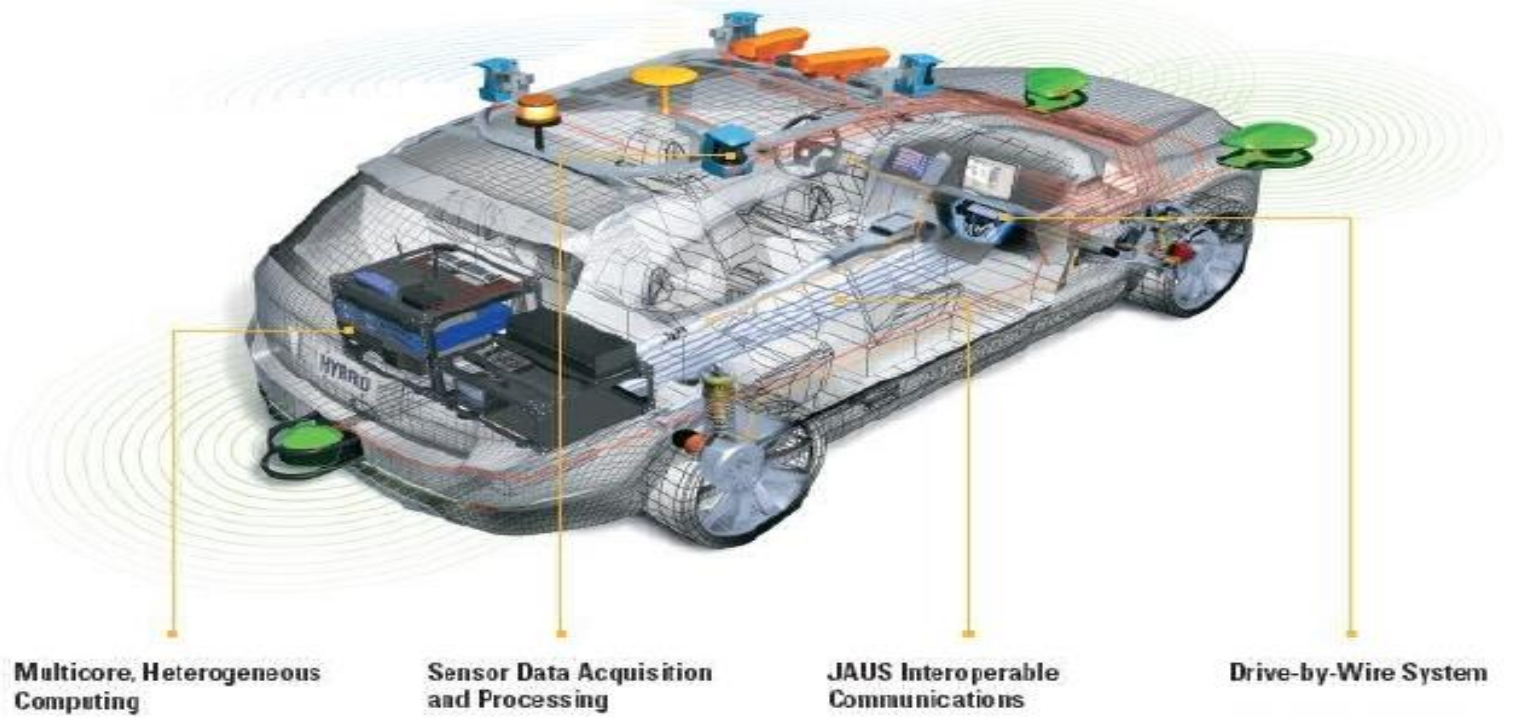

The finger print technologies have been introduced to enter and start your car with the touch of a finger. The fingerprint, which is acting as a key, would trigger a check of the mirrors, steering wheel, radio and temperature to ensure that they're the way you like them. The convenience of fingerprint recognition technology comes with heightened security. Unlike personal identification numbers, passwords and keys, each person's unique fingerprints can't be duplicated, lost or forgotten.

The models for GPS also include aiding sensors, e.g. dead reckoning, radar and camera.

A computer is simply required to feed destination into a dashboard computer. Highly sensitive actuators simulate a human driver completely and direct the vehicle on the road. The vehicle transmitter broadcasts its position and velocity to other immediate participants for collision-avoidance. Forward and reverse motions and u-turns are precisely achieved as per route guidance requirements. Furthermore, an accurate steering control is obtained using Pulse Code Modulation technique and acceleration/braking control is successfully implemented using learning adaptive system

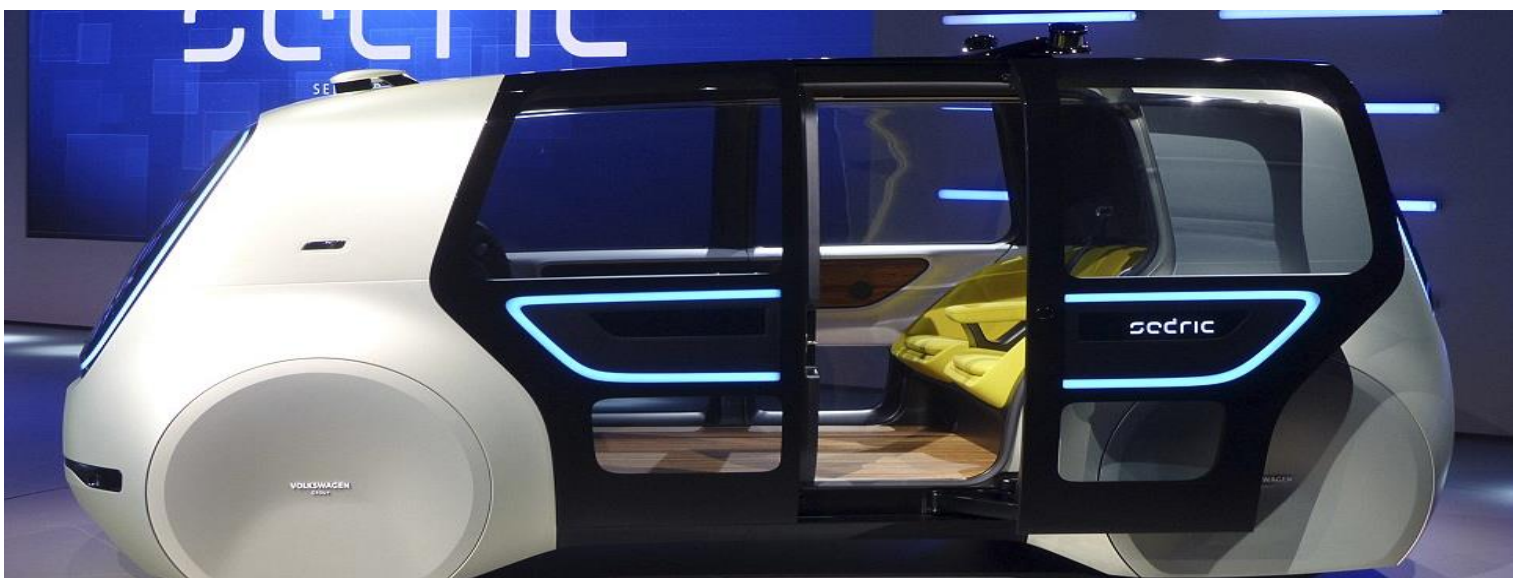



# AIR COOLING EFFECT THROUGH VEHICLE SUSPENSION SYSTEM

By ISH R . RAORANE (TE Mech B)

## Introduction:-

We require fuel efficient car which is possible only when load on the system is less. The vehicle suspension generates mechanical energy which is of two types potential energy and kinetic energy. From this potential energy is stored by shock absorber and kinetic energy is generally wasted. Hence to reduce the load on the system we have to reduce the load on the engine which can be done by using kinetic energy generated in suspension system. The main aim is to produce compressed air using vehicle suspension. This compressed air is then used for air cooling effect in the cabinet of the automobile vehicle.

## Construction:-

### a. Pneumatic cylinder:-

Piston and cylinder is used to convert the atmospheric air into the compressed air. It consists of a cylinder barrel inside which a tight fitting piston can move to and from atmospheric air into the compressed air.

It consists of a cylinder barrel inside which a tight fitting piston can move to and fro.

### b. Non return valve: -

A non-return valve allows a medium to flow in only one direction. It is provide with two ports one for air to enter and other for air to leave.

### d. Storage tank:-

Air Tank is used to store pressurize compressed air & supply this pressurize air when required. The tank is made up of Galvanized iron it will have two ports for inlet and outlet and also, one port for pressure gauge. Pressure Gauge is an indicating device which is connected to the storage tank to indicate the pressure.

### e. Heat exchanger:-

The heat exchanger is used for exchanging heat from one medium to another working medium. It will have copper coil through which compressed air will flow which is to be cooled by exchanging the heat from refrigerant.

## Vehicle Suspension AC system

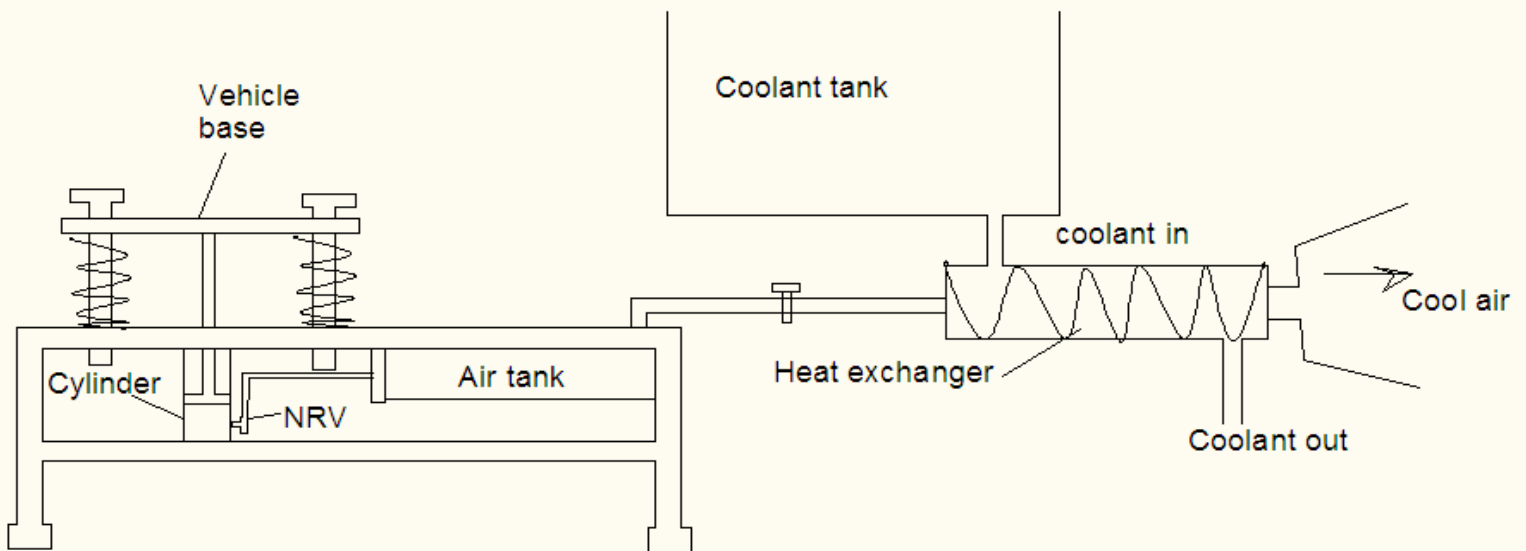

### Working:-

When vehicle run on the bumpy road or uneven road the piston inside the cylinder would move up and down. It would lead to suction of atmospheric air when piston moves from Bottom dead centre to Top dead centre and compresses the air when piston moves from Top dead centre to Bottom dead centre. The outlet port of cylinder is connected the T connector, this connector consist of two portone connecting to the non-return valve and otheris connected to valve which is open to atmosphere. All pressurized air come in tank from cylinder through the pipe connection. The air tank having two ports one is for pressurized air coming from cylinder and other one is for supplying the compressed air as per requirement. The ball valve is fitted to the inlet and outlet of the air tank to control the flow of the pressurized air. And pressure gauge is fitted at other side to show the pressure of the compressed air stored into the air tank. This ball valve is connected to hoses and air is supplied to Heat Exchanger. The heat exchanger is used for exchanging heat from one medium to another working medium. The air is supplied inside tube and cooling refrigerant is supplied outside of tube for producing cooling effect.

### APPLICATIONS:-

The AC systems in suspension can be effectively used in below mention application

1. This system can be used in all recent vehicles.
2. It can be used military trucks and jeeps.
3. It can be used in off road cars.
- 4.It can also be used in sports utility vehicle.

# ROBOTIC SURGERIES- Da Vinci Surgical System

BY SARVESH KADAM (TE Mech A)

Robotic surgery is a type of minimally invasive surgery. “Minimally invasive” means that instead of operating on patients through large incisions, we use miniaturized surgical instruments that fit through a series of quarter-inch incisions. When performing surgery with the da Vinci Si—the world’s most advanced surgical robot—these miniaturized instruments are mounted on three separate robotic arms, allowing the surgeon maximum range of motion and precision. The da Vinci’s fourth arm contains a magnified high-definition 3-D camera that guides the surgeon during the procedure.

The surgeon controls these instruments and the camera from a console located in the operating room. Placing his fingers into the master controls, he is able to operate all four arms of the da Vinci simultaneously while looking through a stereoscopic high-definition monitor that literally places him inside the patient, giving him a better, more detailed 3-D view of the operating site than the human eye can provide. Every movement he makes with the master controls is replicated

eye can provide. Every movement he makes with the master controls is replicated precisely by the robot. When necessary, the surgeon can even change the scale of the robot’s movements: If he selects a three-to-one scale, the tip of the robot’s arm will move just one inch for every three inches the surgeon’s hand moves. And because of the console’s design, the surgeon’s eyes and hands are always perfectly aligned with his view of the surgical site, minimizing surgeon fatigue.

The ultimate effect is to give the surgeon unprecedented control in a minimally invasive environment. As one of our surgeons notes, “It’s as if I’ve miniaturized my body and gone inside the patient.” Utilizing this advanced technology, our surgeons are able to perform a growing number of complex urological, gynaecological, cardiothoracic and general surgical procedures. Since these procedures can now be performed through very small incisions, our patients experience a number of benefits compared to open surgery, including:

- Fewer traumas on the body
- Minimal scarring
- Faster recovery time





# PERPETUAL MOTION MACHINE

BY SURAJ VISHWAKARMA (TE Mech B)

## INTRODUCTION

Perpetual motion machine: A machine which, since set in function, continues to function perpetually without supplying any energy. The question about the perpetual motion machine is one of the issues, which attracts people who tend to believe strange things and occultism. That's why such ideas are adopted from various non-recognized religious circles which often describe in their books or in their speeches perpetual motion machines, which however have neither been manufactured nor have functioned. Usually the members of these organizations ignore the fundamental laws of physics and surely they are not the researchers who possess the knowledge to improve or generalize the laws. On the other side it must be stated that it is not always easy to be proved theoretically that it is impossible for a manufacture to function because in each more complicated system a great number of secondary or inconspicuous activities are involved, which in energy issues

should be taken into consideration. There is also a great number of ideas about perpetual motion machines, which (don't) function with magnets, chemical substances or flame. The «eternal light» without the addition of fuel seems to have been cultivated through the centuries mainly in religious circles. Since the first century A.D. there have been relative descriptions of the Roman military officer, politician, natural philosopher and historian Gaius Plinius Secundus (23-79 A.D.) In these website of Hans-Peter Gramatke there is a detailed presentation of the most known devices for the designing of a perpetual motion machine with pictures, assimilated movements etc.

## **A perpetual motion machine which «functions» with buoyant force**

There have been a lot of efforts to manufacture a perpetual motion machine concerning the production of work with the use of the buoyant force. Motive for the following analysis was a new effort of

# Perpetual Motion Machine



manufacturing a perpetual motion machine, which we prove theoretically, that can't function.

## Theoretical introduction

Supposing we have a container filled with a liquid of density  $d$ , the free surface of which is at a height  $h$  from the bottom. On the bottom of the container there is a parallelepiped of negligible length as shown in below fig. We are going to calculate the work produced during the shift to length  $L$ , of a side with area  $S$  of the elementary parallelepiped of null initial volume, which is in the container at a depth  $h$ , until the parallelepiped acquires volume  $V$ . The force  $F$  that we will apply should be so much that would be able to overcome the force caused by the pressure at the depth  $h$ , that is  $F = PS$  (6) And the consumed work will be:  $W1 = FL$  or  $W1 = PSL$  at last  $W1 = dghV$  (7) If we let the parallelepiped to rise to the surface of the liquid a work will be produced due to the buoyant force:  $W2 = Ah$  or  $W2 = dgVh$  (8) From the Eq 7 and 8 the result is that  $W1 = W2$  (9) Description of the machine The perpetual motion machine that we are examining is composed of a circular disc to which we have adapted weightless  $n$  parallelepipeds, as fig. 4. During the rotation of the disc the parallelepipeds can pass from the lower part of a container which is filled with a liquid via a suitable mechanism so that the liquid cannot slop away.

so the buoyant force will be the moving force for the production of energy.

In fact for each rotation of the disk the buoyant force  $A$  produces a work equal with  $nW1$ . For each rotation, however, is consumed also work for the submersion of the parallelepipeds in the container equal with  $nW2$  in order to overcome force the  $F$  because hydrostatic pressure. But because of Eq 9 we have  $nW1 = nW2$  (10) Therefore the kinetic energy of the disc is not altered, since as much work is produced so much is consumed. That is to say that the machine does not produce any energy. The error of the designer of the particular machine is that he did not take into consideration the force  $F$  because of the hydrostatic pressure and the work that will be consumed for the submersion of the parallelepipeds in the container. In the whole analysis we made we did not include, by no means, frictions. However frictions exist and they will consume any initial kinetic energy we give to the disc with result after a little time it stops

# BE PROJECTS



# Efficient Solar Pounding Machine Using Levers

Kritharth Chaturvedi

Mayank Dubey

Shridhar Ghadigaonkar

Vishal Gupta

**Abstract—:** Many natural resources such as Rock Salt, Chalk and Charcoal are a gift of nature and are a part of day to day human culture, However it is important to process these raw materials in order to put it to conventional usage. Even though most organizations use an Electrical motor based pounding machine, The concern of utilizing Excessive amounts of Non-Renewable Electrical energy which has negative effects on the Environment tends to supersede the value of the profit earned.

Hence it becomes important to come up with solutions where minerals and culinary spices can be pounded with the help of a prime mover which is majorly powered by Conventional sources of energy such as Wind and Sunlight.

**Keywords—**Solar; Pounding; Lever; Gravity; Mechanical Advantage; Ozzo-G

## INTRODUCTION

Materials like Charcoal, Chalk and even exotic spices need to be processed and powdered before putting it to Industrial and Domestic usage. With the advent of Globalization and the rise of in industrial competition, The demand for powdered goods has increased drastically. In order to fulfill the demands and satisfy each customer, Many Large and medium scale organizations have taken aid of Electrically powered pounding machines in order to meet Large customer demands and reduce the cost involved in employing Skilled and Unskilled labor.

## LEVER PRINCIPLE & MECHANICAL ADVANTAGE

Even though most organizations use an Electrical motor based pounding machine, The concern of utilizing Excessive amounts of Non-Renewable Electrical energy which has negative effects on the Environment tends to supersede the value of the profit earned. The project deals with this problem triumphantly by using the Lever based Ozzo-G engine. Lever Principle and Mechanical Advantage. "Give me a place to stand on, and I will move the earth." said the great greek mathematician and physicist Archimedes. A lever is a machine consisting of a beam or rigid rod pivoted at a fixed hinge, or fulcrum. A lever is a rigid body capable of rotating on a point on itself. On the basis of the location of fulcrum, load and effort, Maintaining the Integrity of the Specifications. The principle of levers can also be understood by Varignon's Theorem of moments which states that the moment of a resultant of two concurrent forces about any point is equal to the algebraic sum of the moments of its components about the same point.[5]

In other words, "If many coplanar forces are acting on a body, then the algebraic sum of moments of all the forces about a point in the plane of the forces is equal to the moment of their resultant about the same point[1].

$$\sum_i \mathbf{M}_{O_1}^{u_i} = (\mathbf{O} - \mathbf{O}_1) \times \left( \sum_i \mathbf{u}_i \right) = (\mathbf{O} - \mathbf{O}_1) \times \mathbf{R} = \mathbf{M}_{O_1}^{\mathbf{R}}$$

Mechanical advantage is a measure of the force amplification achieved by using a tool, mechanical device or machine system. The device preserves the input power and simply trades off forces against movement to obtain a desired amplification in the output force. The model for this is the law of the lever.

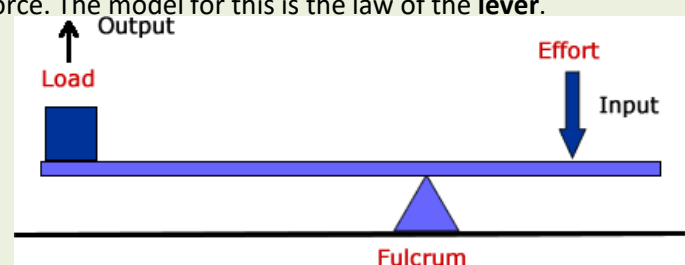

A children's seesaw is a great example of day to day life mechanical elements that work on Mechanical Advantage.

## THE LEVER ENGINE

Perpetual machines are those machines which run continuously. As we know any machine to run continuously we need a force to be always acting on it to run it continuously in Modern day Mechanics. It is only possible when input is more than output. So perpetual machines are impossible as per Newton's third law of motion. But as we know science is far ahead beyond Newton's classical laws; And lever principle provides an output far greater than the input provided by the principle of conservation of moment or Varignon's theorem.[3]

The lever engine (Ozzo-G) provides a larger output by lifting a weight of approximately 140kg by providing a nominal input of 100-200 watt.

This is possible due to the obtained Mechanical advantage in the lever assembly because of which the machine takes minimum input to produce a larger output and therefore behaving somewhat like a perpetual machine. The Elements and assembly of lever engine is covered in the forthcoming chapters.



.fig III .a. Lever Engine



Fig IV. A Conventional Pounding Machine

## POUNDING MACHINE

Pounding Machines are machines which are also known as Kandap Machine. It is used for pounding spices making powders of grains. A pounding machine consists of a set of heavy steel pounds, loosely held vertically in a frame, in which the pounds can slide up and down. They are lifted by cams on a horizontal rotating shaft. In our pounding machine, the camshaft is arranged to lift the pounds from the side, so that it causes the pound to rotate. As the camshaft moves from under the pounds, the pounds falls onto the material below, crushing the rock, spices, roots etc and the lifting process is repeated at the next pass of the cam. Jas enterprise specially designed lever to lock or unlock the pounding process. grading can be done while hammering is locked (stopped) / unlocked.

We want to make efficient pounding machines which can be powered by solar. Presently majority of pounding machines have lever.[2] The lever fulcrum in existing lever is towards at force arm end of the lever. Solar Pounding Machines we want to put fulcrum towards load arm end to get mechanical advantage. So we will be using lever engine called Ozzo-G lever engine. We want to keep rpm approximately 100 pounding per minute, Single Pound. We want to use 100 watt Photo Voltaic Panel to run the same. And pounding machine input power to be at 60 watt approximately. Pounding has been important procedure for making powder of any important step. Normal Pounding machine takes lot of energy.[4] In country like India electricity is not available at every nook and corner or if available it's very low voltage. So pounding at these places is done manually, which is time consuming and inefficient. So to tackle these problems we are designing pounding machine which working on lever principle consume less energy. And if it is integrated with solar panel that electrical energy is also not needed

The Lever based pounding system takes assistance of a Lever engine whose dimensions are listed below:

Lever	Structure: I Beam ISO MB100 Material Used: Cast Iron Free End To Fulcrum Distance: 1155mm Free End To Connecting Rod Distance: 220mm Total Length Of Lever: 1560mm
Dead weight Flywheel	Weight: 70kg Material Used: Cast Iron Diameter of flywheel: 560mm Weight of flywheel: 70kg Diameter of flywheel shaft: 30mm
Bearing	SKF Pillow Block Bearing P208
Electrical Motor	Siemens IS/TEC 60034-1 3 Phase Induction motor % efficiency: 75.7 % Power: 1.5 kW Max speed: 945 rpm
Structure	I Beam: IS MB100 C Beam: IS MC100 L Clamp: IS 65x65x6 Width: 57.5mm Height: 1310mm Length: 1680mm

which working Along with the above elements, The necessary and required elements of the pounding system are:

1. Hammer(s)
2. Hammer Guide plates
3. Cam
4. Cylindrical vessel
5. Linkages
6. Pivot

Ozzo – G Engine is a Mechanical Multiplier Gravity Engine which takes less mechanical power and output multiple times more than the mechanical power. It multiplies the input power and gives the output which is higher as compared to power consumed. This power is then used to obtain the required force to obtain the crushed/powdered material. One of the most important aspects of the design of such a machine is determining the ideal position of the hammer on the lever.

The problem is solved by placing the hammer at the outmost extent on the lever. This is done in order to obtain the maximum speed of pounding along with sufficient pounding weight. A weight of approximately 3Kg is desirable for the hammer in order to obtain the powdered product.

# Human Transporter-Cum-Forklift

**Abstract**—The system proposed in this paper is a solution to the transportation problems arising in the manufacturing industries. An electric personal transport is a vehicle which can carry persons from one place to another there are many kind of personal transporter and in that one type is stand up transportation vehicles these are used for traveling short distances so as to reach the destination in no time these vehicles are light in weight and some are so compact that they can be carried along the way. The Segway Human Transporter (HT) was a revolutionary new way of moving people around. A forklift is basically a powered industrial truck used to lift & move materials over short distance. Here, we introduce our idea of project in combining these two ergonomically designed machines to obtain the result i.e. a human transporter which will also be having ability to carry the material and maneuver within the industry.

**Keywords**—*Human Transporter (HT), Forklift, Ergonomic, Vehicle*

## INTRODUCTION

Today the world is now going to be compact. For suitability to the world, things are also going to be made of compact and smaller in size. Now the battle is also done between machines instead of man to man. Machine, which are fighting, are operated and driven by man sitting instead the vehicle or being in touch with the machines. Also the human has to win the war against the increasing oil prizes and tremendously increasing pollution level in the air. To win this war and to thought regarding the another parallel motive force to the auto-mobile, we have thought of manufacturing “Personal transporter” through the mission of project.

An electric personal transport is a vehicle which can carry persons from one place to another there are many kind of personal transporter and in that one type is stand up transportation vehicles these are used for traveling short distances so as to reach the destination in no time these vehicles are light in weight and some are so compact that they can be carried along the way. The Segway Human Transporter (HT) was a revolutionary new way of moving people around. Consisting of a standing platform between two coaxial wheels with handlebars protruding up from it, its stability seems an impossible feat. Due to a very robust and responsive control system coupled with various sensors and actuators, the Segway.

. So to replace the electronic components we have implemented the third wheel and differential to steer the transporter. So now our idea of developing this Human Transporter is incorporated by a simple forklift which is used in industries, & at present is not available in the market for sale. Formatter will need to create these components, incorporating the applicable criteria that follow

## METHODOLOGY

*Phase 1:* Phase one includes survey of industries and manufacturing plants regarding issues and obstacles faced while designing, transportation on the production floor. Modern manufacturing process have become efficient while some issues do occur on the production floor. Miscellaneous problems like human error, natural calamities do occur without prior notice which affect and hamper the process of industries.

*Phase 2:* Phase two involves problem identification based on surveys and pole taken by our team in various production facilities, thereby providing a clearer view of the solution to be required and setting a proper planed course of action. This in turn helps us to clarify the requirements that provide a useful and affective solution which help disappearing the problems faced during manufacturing process. Reducing the wastage of resources is the key for designing effective solutions.

*Phase 3:* Phase three involves careful research based on the current problems faced as manufacturers and to provide a platform to enable them to work efficiently by eliminating the obstacles faced, which are responsAt this point our team prepared for a simple inter-plant transport electric vehicle design which helps eliminate space wastage, investments in machines and expense for skilled labor.

*Phase 4:* Phase four involves careful prototyping and testing of the project once the design and fabrication has begun. The goal here is to reduce custom parts and designing mechanisms requiring standardized parts available easily in market. Convenient and ergonomic structures for ease of use and light weight, easy to maintain vehicle are the endeavors aspired to be achieved.

*Phase 5:* Phase five includes final product designing and testing before being submitted and presented. This stage involves testing on incline plane, decline plane, steering on dry, wet and rough surfaces. Max payload testing will be done with increasing weights and counter weights will be used to balance out any unbalancing issues. Once every part performs under safe loads successfully, the product will be finalized.

ible to reduce the overall efficiency of the plant

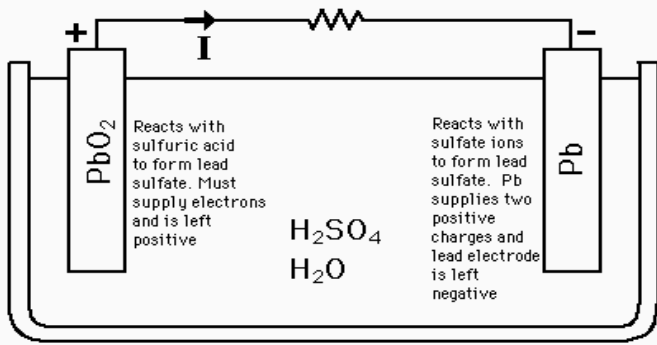

**WORKING**

Human Transporter Cum Forklift as the name suggests is an electric vehicle with two wheels at the rear and one follower wheel at the front working on pure electric principles. Two electric drives are used. 1] To propel the vehicle in all directions and 2] To drive the forks.

One electric motor is mated to a worm and worm wheel gear reduction gear box which is used to increase torque output of the motor. The drive shaft from the gearbox is fixed to a pulley. A 50:50 torque distribution rear differential is used to transfer power to both the rear wheels and is mated to the gear box via a belt drive.

The front end of the vehicle balances on a follower wheel which is used to steer the vehicle even in tight and small areas. This wheel is connected to the handlebar that is directly welded and does not include any complex rack and pinion mechanisms. The drive axles are mounted on two pedestal bearings and the battery pack is placed at the rear end of the vehicle so as to provide as counter weight for the forklifts pay loading.

The forklift mechanism is a retractable design i.e. it can be extended manually as and when required. A separate moto drive will be provided to lift the forks with the help of chains and sprockets.

The vehicle will be provided with a foot pedal that completes the circuit which in turn helps to move the vehicle. A control switch will be provided at the handle bar which actuates the forks to move upwards or downwards, depending on the operator requirement.

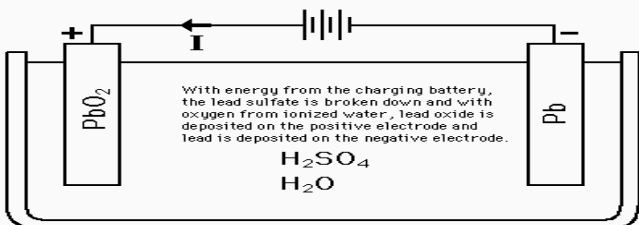

**FUTURE SCOPE**

The desire to reduce operator fatigue while travelling from one work station to the other and thereby increasing to cumulative work output of an industrial manufacturing plant can be achieved by providing easy inter-plant transport vehicles.

Reducing the total cost of investment for separate transport vehicles and forklifts will be eliminated by investing just one vehicle that does it all.

Greener modes of transportation is a dire need of the 21<sup>st</sup> century as air pollution is on the rise and fuel reserves are depleting. Electric vehicles are much cleaner and provide a perfect platform for a variety of applications.

Electrode connected to spongy lead plates

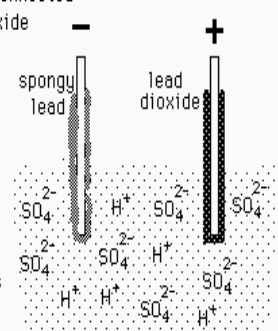
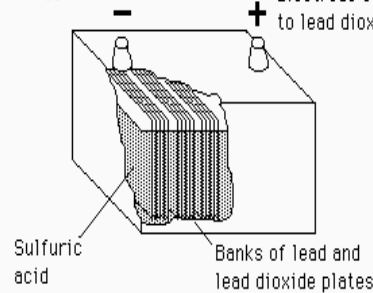

**CONCLUSION**

Large manufacturing plants have vast floor area with different work stations spread throughout the space. It becomes mandatory for operators to travel from one workstation to the other. Moving about repeatedly causes operator fatigue which can lead to reduced awareness and performance over time. This can cause accidents and cumulatively affect the production efficiency. 'Human Transporter-cum-Forklift', eliminates this via it's compact, ergonomic form and clean method of travelling across the plant. It is an electric rear wheel drive vehicle which provides a platform for the operator to stand as well as houses a forklift in the front. Due to its simple design, this vehicle can easily be manufactured and maintained my industries belonging to any discipline.

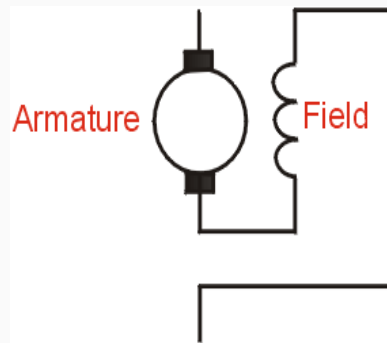

Series Connected Motor

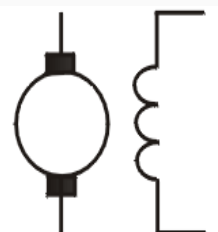

Separately Excited Motor (SEPEX)

# AUTOMATIC DENIM CREATOR (ADC)

Prof. Mahendra Shelar

SAURABH VAIDYA, DEEP VIRA, NITESH SINGH

**Abstract:** *Automatic Denim Creator (ADC) is a worktable designed such that it is an automated CNC denim sprayer that can coat denims with miscellaneous chemicals to produce fading effect on jeans to live up to the expectation of the latest market trends. This machine is designed to reduce the impact of the harmful chemical used during the process on human body and environment. The working principle of this machine is same as that of a 3 Axis CNC. The coating of various chemicals on denim such as Potassium Permanganate ( $KMnO_4$ ) oxidizes the natural color of the indigo material and hence produces a fading effect. Due to increasing trend of denims in today's date, ADC not only ensures high accuracy of spraying technique which is very important in today's competitive market, but also ensures its adaptability to upcoming trends. This will in return help the consumer in optimizing the same machine for upcoming years. Hence proving to be cost effective.*

## INTRODUCTION

We have designed ADC to eliminate the hazardous effect on human body during the manufacturing of a denim. ADC is a CNC machine which can replicate human arm motion to spray coat denims with different chemicals in an isolated environment. This machine can spray each denim within 20 seconds which is 4 times faster than a human. Thus reducing requirements of skilled labor and reducing the overall cost of manufacturing

## REVIEW OF LITERATURE

Potassium permanganate spray is done on jeans to take a bright effect on sand blast area. An important thing about potassium permanganate spray is, this is usually a sporting process to increase the effect of sand blast. Potassium permanganate solution is sprayed on sand blasted area of jeans garment with the help of normal spray gun. This chemical spray appears pink on garment when fresh and turns to muddy brown on drying. The garment is hanged in open to dry after spraying and when the potassium permanganate turns its colours completely then it is considered to ready for next process.

## METHODOLOGY

We will be dividing the methodology into 5 major steps: -

We have done a tie up with **Spykar** jeans which is one of the biggest denim manufacturing brand in the country. This tie up gives us the very access to all the manufacturing plants of spykar and the data of the chemicals and processes they use to make high quality jeans. By studying the manufacturing processes we are learning how a denim is made at first.

Prototype designing using SolidWorks: Using solid works we are designing the machine part by part and then assembling it. This will help us later during fabrication as the solidworks design we will directly feed to the laser cutting CNC's. Also we will get a better vision of how the prototype will look. Also one can leverage 3D design data to quickly [communicate](#) complex technical details with animations and visual instructions.







Stress analysis using ANSYS WORKBENCH: With limited resources and limited time available the room for mistakes and errors is not available. To make sure that no errors are left out during design we are using this software to check for all the stress and make sure that no part under goes failure once the machine is made

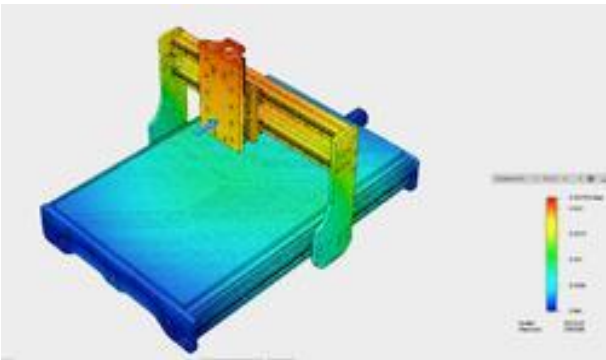

Laser cutting and frame development: Since the machine we have intended to make requires very high precision and accuracy. Such high quality of manufacturing cannot be achieved by manual methods of fabrications.

Installation of electrical controller & PLC: The most important components of any automatic machine is its electronic hardware. We will be installing servo kit by **Motiontek**, which will include driver, controller, breaker, contactor, Ac servo motor, and plc as well

**WORKING**

ADC is designed to minimize the impact of the chemicals used to manufacture the denim. Thus the process of spraying KMnO4 is done in an isolated chamber. The loading of denim has to be done manually. A loader initially loads a completely stitched jeans on the air filled rubber dummies (AFRD). Once the placement of the denim is crosschecked by the operator, he starts the machine. The AFRD then goes into the isolation chamber with the help of the overhead conveyor. Once the AFRD is in position the 3-Axis CNC starts to coat the jeans as per the design that was initially feed into the master computer. Once the spray is completed the AFRD come out of the chamber with the overhead conveyor. Here the process of unloading the coated jeans and loading the new jeans is done.

**ACRONYMS**

**ADC: Automatic denim creator.**

*CAD*: Computer aided designed.

*CAGR*: Compound annual growth rate.

*AFRD*: Air filled rubber dummies

**CONCLUSION**

Hence ADC is not only an effective but also a cost efficient way to replace the convention KMnO4 spraying method. Manufacturing and setup cost will be far less. However, our main objective of successfully creating a safe work environment for the workers is achieved. India being one of the biggest manufacturer and consumer of denims, it lacks automation and hence we aim to change this. We hence conclude that ADC has a vast scope not only in India but also other international markets and will help India achieve number one position in manufacturing industry with coordination of humans and machines.

# INTERVIEW

## Mr. Mahesh Kulkarni

{Senior Principal Engineering Mechanical Mumbai( Technical FMC) }

### •What is your opinion about TCET?

TCET is working hard for developing students to good professional engineers by out of the box thinking and implementation of these ideas into reality. In present day and age, most of the students are studying for exams and not for knowledge. TCET is taking extra efforts to change this attitude. Students are also required to acknowledge these efforts from the college and share their thoughts with the faculty members to achieve combined goals.

### •What is your opinion about Mechanical Engineering Department and students?

The Mechanical Engineering Department is taking a lot of effort to be up to date with the technological advances being made in the field of mechanical engineering. The students take complete advantage of the faculties' expertise by asking for their guidance while making their projects. Students actively participate in various competitions wherein they make projects and present their ideas.

### •How to improve the knowledge to become a professional Engineer?

Professional engineers need to have strong grasp on their technical knowledge, should be aware of the requirements of the industry and should be able to apply the concepts they have learnt to real life

The background of the entire page is a dark, monochromatic image of numerous interlocking gears of various sizes and orientations, creating a complex, mechanical pattern.

problems. For this students should get certifications of various softwares used in the industry for designing structures. Participation in different national level project making competitions will give them practical experience. Apart from working on their technical skills, students need to work on their soft skills. Participating in technical paper presentation competitions and debates will enhance their confidence.

- How to improve skills in faculties?

Going on international level training programs will improve their technical skills. Increased interaction with students will be very beneficial for the students. Taking feedback from the students will help lessen the communication barrier between the two.

- How to improve placements in core company?

The college should provide students with core industry specific courses. Helping students get long term internships in core companies will improve students' chances of getting placed greatly. Certification courses, participation in national level project making competitions, co-curricular and extra-curricular activities will help in the all round development of students.



Zephyr, our annual technical festival organised during month of September, it was a tremendous success. Approximately 6,000 participants and visitors contributed towards this festival which was held for 3 days.

The first day was highlighted by events like 'IC Racers', 'IC Jumble' and 'Project Exhibition'. The other events included a blend of technical and nontechnical events. Events like 'Treasure Hunt', 'Minute to win it', 'Rubix Cube' and 'Glow carrom' has a great response from participants. It was a social event conducted with the intent of raising awareness about environmental issues at the individual and local level.



# FEST

# SOJOURN

Sojourn is a cultural fest where our engineering students are able to unveil their talent on the much isolated turf of performing arts. It is one of the most eagerly awaited college activities of the year. It is an inspiration and dedication to the trends that made waves. Also setting a trend, the festival has ventured into the Inter-Collegiate arena.

The campus ablaze with enthusiasm exhibited by students in events like Fashion Show, Nach baliye, Drama, Laughter Challenge, Debates, GDs, and much more.





## HEATREATERS & ENGINEERS

*Heatreaters & Engineers is a private heating equipment retailer in Mumbai, Maharashtra. The organization is located at Ashok Silk Mills Lane, Off Lbs Marg..*

**Event Details:** One day Industrial visit to Heatreaters & Engineers, & EXOVA metallurgical services on 15th September 2017 for SE Mechanical students.

**Duration:** 15 September 2017 (one day)

**Venue:** Ashok Silk Mills Lane, Ghatkopar West, Mumbai - 400086

**Participants:** SE Mechanical Engineering Students (30) and Faculty Members (03)

### Heatreaters & Engineers:

Heatreaters & Engineers is a private heating equipment retailer in Mumbai, Maharashtra. The organization is located at Ashok Silk Mills Lane, Off Lbs Marg.

Revenue:

The organization generates \$379,571 in estimated sales, or approximately ₹25.2M INR.

Employees:

Heatreaters & Engineers employs 60 people. In Mumbai, an average company has between 9 and 161 employees, meaning that Heatreaters & Engineers employs a typical amount of people.

This company has two types of furnaces-

- a] Electric furnace
- b] Gas furnace

Electric furnace is insulated with white **glass ceramic fibres**.

Various Thermocouples made of **NICHROME WIRES** are used for measuring temperature inside furnaces

This furnace can withstand upto 1500 degree centigrade.

In Gas furnace 12 thermocouples are placed for various temperature measurements which are connected to 12 point cartridge to determine different thermocouple readings.

All 12 colours gives a graphical representation of temperature v/s time graph.

In above graph , X-axis represents temperature and Y-axis represents time.

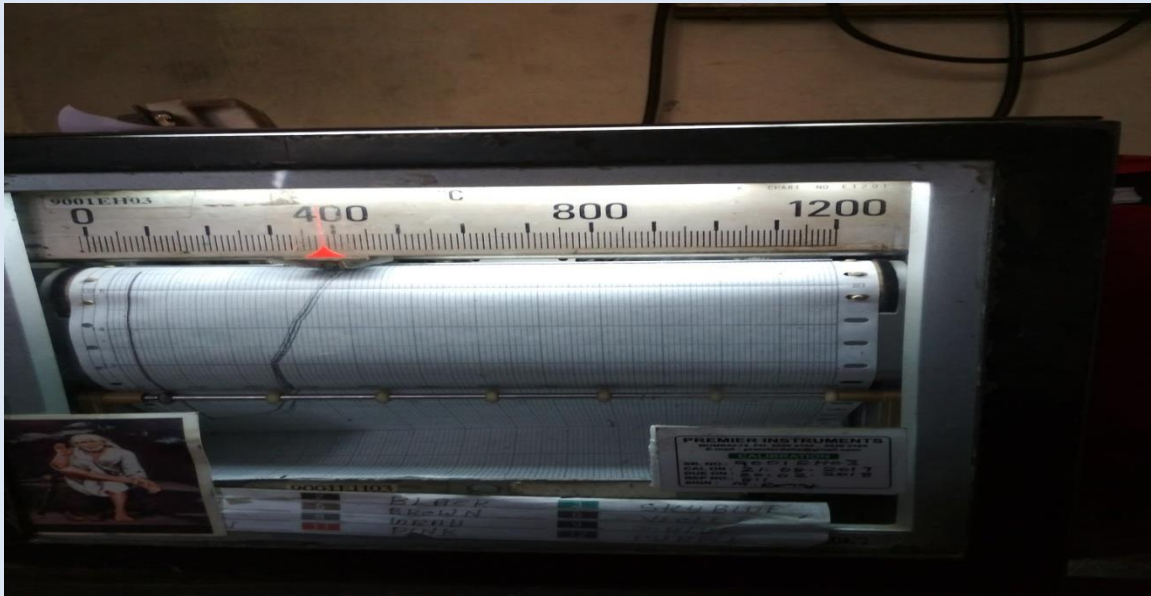

## EXOVA METALLURGICAL SERVICES

With 50 years' experience, Metallurgical Services Private Ltd (A group company of Exova) is synonymous with quality material testing in India. Our 10000 sq.ft. laboratory along with over a 150 skilled experts is one of the few to offer an entire spectrum of material testing services.

Metallurgical Services Pvt. Ltd. was acquired in July 2014, by Exova Group Plc. Exova is one of the world's leading laboratory-based testing groups, trusted by organisations to test and advice on the safety, quality and performance of their products and operations

Exova operates 118 permanent facilities in 23 countries and employs more than 3,800 experts throughout Europe, the Americas, the Middle East and Asia/Asia Pacific. Exova's capabilities help to extend asset life, bring predictability to applications, and shorten the time to market for customers' products, processes and materials. With over 90 years' experience, Exova specialises in testing across a number of key sectors from health sciences to aerospace, transportation, oil and gas, fire, industrials and infrastructure.

This laboratory performs various test of **chemical , water , mechanical , corrosion & various other tests.**

**ICG Testing is done as per following condition :**

ICG TYPE	CHEMICALS	TEMPERATURE	DURATION
1] C	NITRIC ACID	110°C	10 DAYS
2] B	CuSO <sub>4</sub>	120°C	16 HOURS
3] E	Fe <sub>3</sub> SO <sub>4</sub>	120°C	5 DAYS



Different machines are there for various purposes as follows:

**CUTOFF Machine** for Calcium Chloride Corrosion Test.

**SPECTROMETER** using light energy it gives composition of materials.

**LECO C 5230 - Carbon Sulphur Analyzer**

**LECO TC 136 - Oxygen Nitrogen Analyzer**

**EMISSION SPECTROMETER** - A portable machine for finding composition of material elements other than Cr,Mn,Fe,Ni,Cu,etc.

**MTS 810**-An American machine for AEROSPACE material testing of **ISRO** & also in **SUBMARINE** metal testing.



# ASME - CORE



(Shrey-Suraj-Shivani-Ritu-Sarvesh-Abhishek-Mihir-Kaustubh)

SARVESH KADAM

Chairperson

RITU SHAH

Vice-Chairperson

MIHIR NAIK

Marketing Head

SURAJ VISHWAKARMA

Treasurer

KAUSTUBH PATIL

Event Manager

ABHISHEK NARAYANAN

Secretary

SHIVANI VELLPURE

PUBLICATION HEAD

SHREY GUPTA

HOC Student Co-ordinator

# ACHIEVEMENTS

Uddhav Karvir, Prasad Bagwe,  
Deepak Gupta, Omkar Bhogale and  
Niraj Chauhan.

2nd in IIT Kanpur Techkriti IC RC Racing  
4th in IIT Bombay TechFest Full Throttle



# ACHIEVEMENTS

Saurabh Vaidya & Deep Vira  
1st in Thadomal Sahani Engineering College  
1st in L. R. Tiwari CoE  
3rd in SPIT



# ACHIEVEMENTS

## Pratiksha Das

Part of India's first Women's Racing team  
4th in Car drag race in Aamby valley Air Strip (India Speed Week)  
5th in MRF National Bike Racing Championship



